

RECOMMENDED STRUCTURAL FRAMING EQUIPMENT SCREENS / VISION BARRIERS

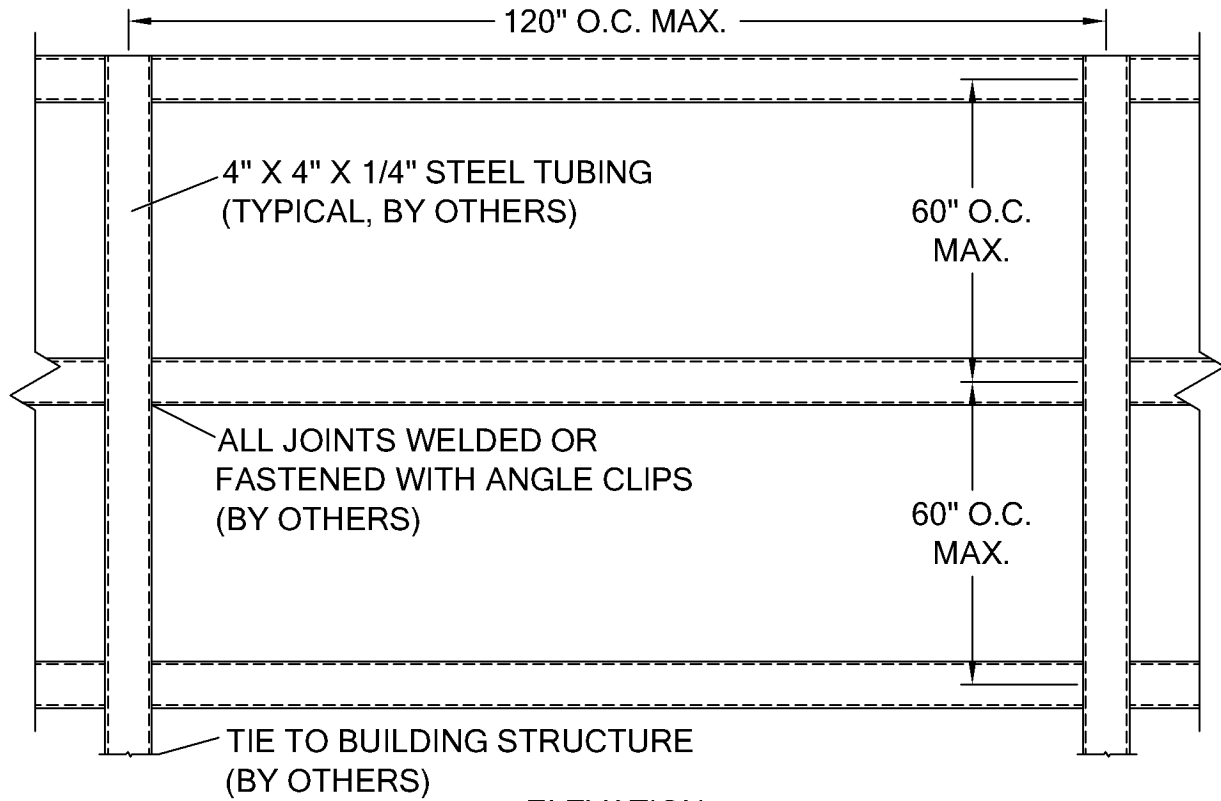

ELEVATION

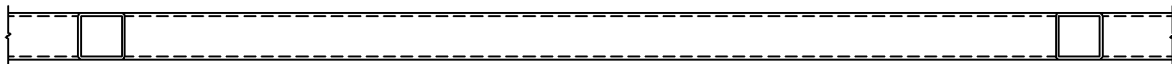

SECTION

RECOMMENDED STRUCTURAL FRAMING SUPPORT FOR EQUIPMENT SCREENS (BY OTHERS)

NOTE: LOUVERED SCREENS REQUIRE STRUCTURAL SUPPORT EVERY 60" O.C. OF VERTICAL OR HORIZONTAL SPACING (TO MEET 100 MPH WIND LOAD). MAXIMUM HEIGHT OF SCREEN WITH THIS CONFIGURATION IS 96". TALLER SCREENS WILL REQUIRE LARGER STRUCTURAL MEMBERS.

**ARCHITECTURAL
L·O·U·V·E·R·S**

7684 Coldbrook Lane - Cincinnati, OH 45255
PH: (888) 568-8371 Fax: (888) 568-8370

PROJECT			
CONTRACTOR			
ARCHITECT			
DRAWN BY: JRR	DATE: 08/2007	DRAWING TYPE: TECHNICAL SHEET	DRAWING TITLE: INSTALL INSTR ES